

DL - 17/23 BASIC TUMBLE DRYERS

P PROGRAMMER

New P programmer: push buttons to control temperature and time

OUTSTANDING FEATURES

Reversing drum action as standard
Galvanized drum as standard
Frequency inverter as standard

EFFICIENCY

Big fluff filter

VERSATILITY

Make to order- customisation
OPL > Multivending- Standard OPL model easily transformable to coin laundry uses



ERGONOMICS

Drawer as fluff filter, made of stainless steel
Biggest door diameters
Opening sense of door adjustable on site



MAINTENANCE

Hinged panel: easy and ergonomic access
Technical menu: statistics, alarm, autotest, data recovery for technicians and maintenance (with console option)



OTHERS

White painted panels.
LINT FILTER: filter drawer with wide surface and improved airflow.
COOL DOWN- anti-wrinkle at the end of the cycle
Heating options: electric and gas
CE approved



OPTIONS

- Opposite door opening
- Display for P programmer
- Ship voltage for electric models: 440V III 50/60 Hz No neutral

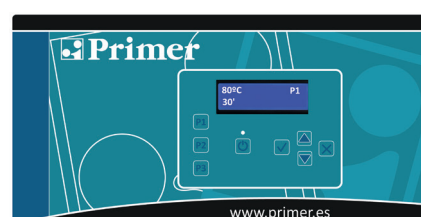

P Control with display

TECHNICAL DATA	UNIT.	DL-17		DL-23	
CAPACITY					
Capacity 1/18	Kg	18		26	
Capacity 1/20	Kg	17		23	
Hourly Output BASIC*	Kg/h	35-33		41-35	
Evaporation capacity BASIC*	l/h	16,3		20,4	
DRUM					
Ø Drum	mm	750		855	
Ø Door	mm	574		574	
Door center height	mm	976		1.030	
Load hole bottom height	mm	689		743	
Drum length	mm	746		800	
Drum volume	l	330		460	
POWER					
Drum motor power	Kw	0,37		0,37	
Fan motor power BASIC	Kw	0,25		0,55	
Electric heating power ALL RANGES	Kw	18		24	
Total electric power (elec.model) BASIC	Kw	18,67		24,97	
Gas heating power ALL RANGES	Kw	20,51		31	
Gas heating power (gas model) BASIC	Kw	0,67		0,97	
CONNECTIONS		ELECTRICAL		GAS	
Tension 230V - I + N + T	Nº x mm2 / A	-		3 x 1,5 / 20A	
Tension 230V - III + T	Nº x mm2 / A	4 x 16 / 63A		3 x 1,5 / 20A	
Tension 400V - III + N + T	Nº x mm2 / A	5 x 10 / 32A		5 x 10 / 40A	
Ø Gas inlet	BSP	1/2"		1/2"	
DIMENSIONS / PACKING DIMENSIONS					
Net width / Gross width	mm	785 / 865		890/970	
Net Depth / Gross Depth	mm	1.125 / 1.210		1.255/1.345	
Net Height / Gross Height	mm	1.694 / 1.840		1.812/1.940	
Height without heating battery	mm	-		-	
Net weight / Gross weight	Kg	187 / 200		210/230	
OTHERS					
Max airflow BASIC	m3/h	850		1.200	
Ø Fume exhaust	mm	200		200	
Sound level BASIC	dB	64		65	

* It may vary depending on the type of heating, filter cleanliness or extraction type.

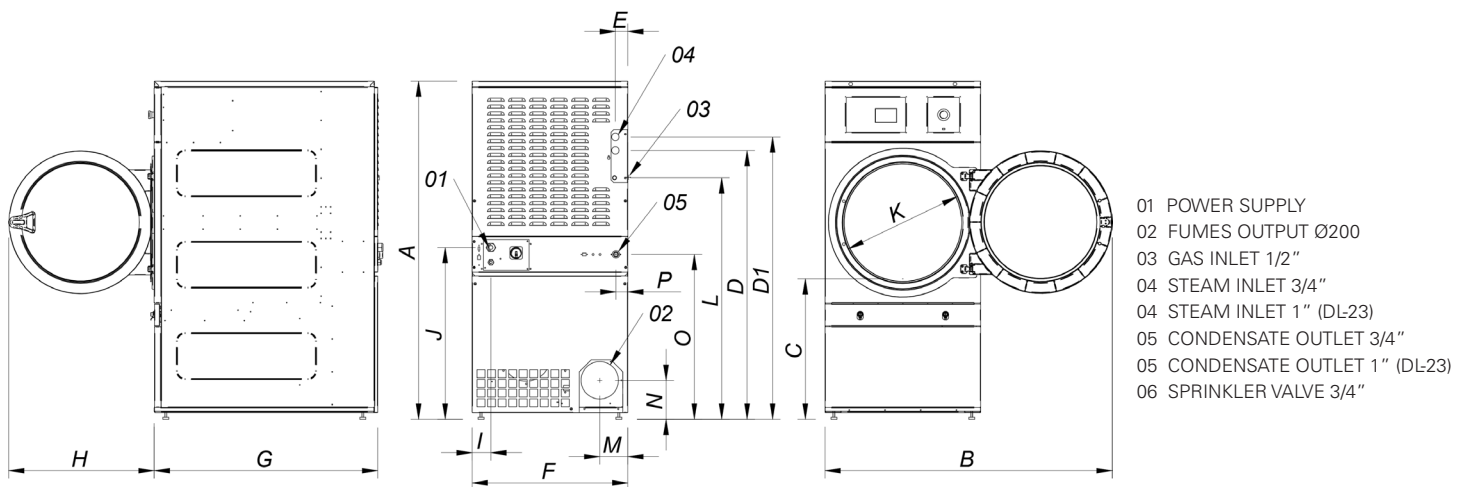

	A	B	C	D	D1	E	E1	F	G	H	I	J	K	L	M	N	O	P
DL-17	1694	1447	689	1354	1422	68	68	785	1125	735	95	870	575	1226	133	180	830	65
DL-23	1812	1552	743	1430	1532	112	55	890	1255	735	95	920	575	1344	238	180	885	65

